

EO-MD-63183

**EKSMA OPTICS**

**635nm Laser Diode Module**

**635nm less 18mW dia 9,8mm Laser Diode Module (Class IIIb)**

**EO-MD-63183**

■ Specifications : (Tc=25°C +/- 3°C)

Item	Characterization	Remark
Laser spot	Circle	
Applicable Lens	A plastic lens for each unit	
Wire	26 AWG PVC-Free	
Solder Material	NIHON GENMA SOLDER (Lead-Free)、NP 303 YS RMA 0.8 mm & NP601 SZ 555 GK	
Body	Brass	

■ External dimensions : (Unit : mm)

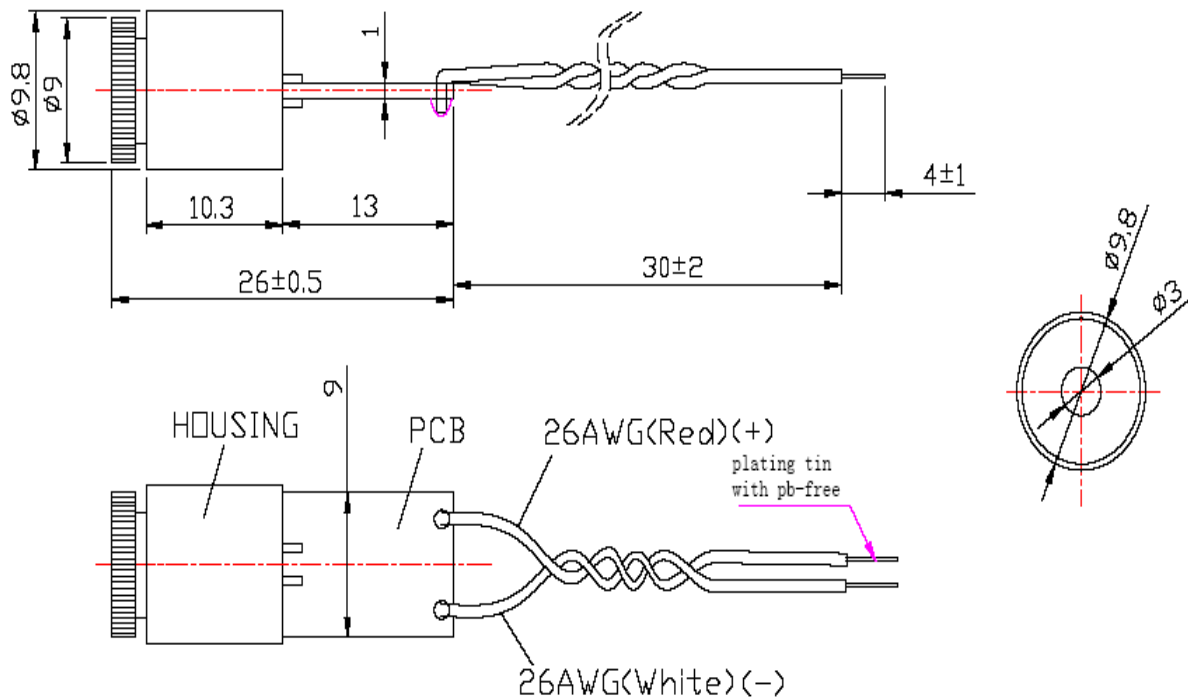

Default tolerance : +/- 0.3

■ Environment Condition :

Parameter	Min.	Typ.	Max.	Unit	Remark
Storage Temperature and Humidity	-25	-	70	°C	Storage in 3 weeks
	40	-	95	Rh	
Operating Temperature and Humidity	0	-	40	°C	No Condense
	20	-	80	Rh	

**635nm Laser Diode Module**

■Electrical and Optical Characteristics : (Tc=25°C +/- 3°C)

Parameter	Min.	Typ.	Max.	Unit	Remark
Input power source	-	5	-	Volt	±10%
Consumption Current	-	80	100	mA	
Output power	16	-	18	mW	Class IIIb
Beam Dimension (Output Aperture)	-	3.5 X 1.7 (±0.5)	-	mm	No ghost spot at 3M
Beam Dimension @6m	Φ10	-	Φ15	mm	
Wavelength	620	635	640	nm	
Life Time	-	10000	-	hrs	

\* Wire Definition : DC +3.1V -- Red color, GND -- White color

■Reliability test :

Item	Characterization	Remark
Vibration test	Depend on customer	
Drop test	8 times at 1 meter after packing	
Voltage test	4.5V ~ 5.5V	
Temperature test	0°C ~ 40°C	

■Precautions

■Heat Sinking :

If the case temperature of the laser diode exceeds its maximum specification, premature or catastrophic failure may occur. To ensure the maximum life of the laser diode, it is recommended that an additional electrically insulated heatsink, of at least 35sq.cm. be used. Thermal transfer cream can be used to improve contact and heat dissipation. Do not restrict air circulation around the device.

■Power Connections :

The Compact laser diode modules require a regulated input voltage of 4.5-5.5V DC. Connections are made via the 2 pre-tinned external flying leads, (red is positive, white is negative).

**WARNING:** The housing is internally connected to the positive supply rail.  
Specifications subject to change without notice.

■Laser Safety Precautions :

1. Do not look into the laser beam directly by eyes. The laser beam may cause severe damage to human eyes.
2. Optical Lens is made of plastic or glass . Do not contaminate lens by soiling, oil or chemical.